

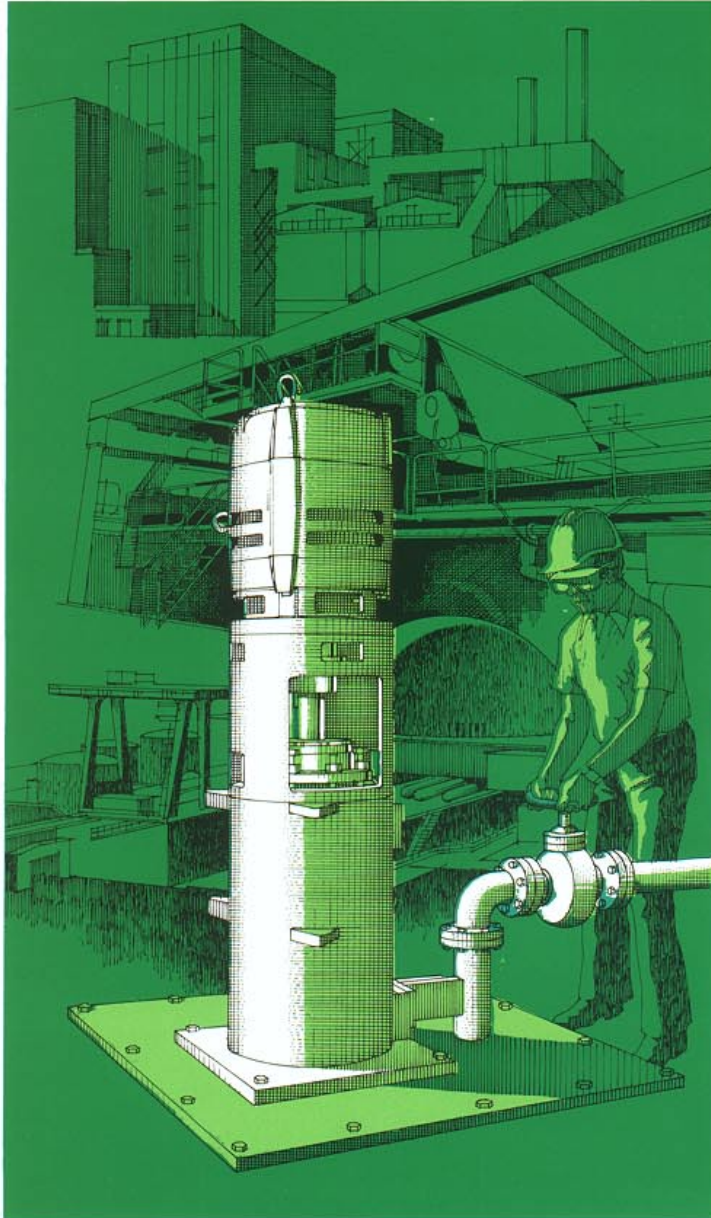

Goulds Model VHS Vertical Cantilever Recessed Impeller Pumps



Goulds Pumps



ITT Industries
Engineered for life



Goolds Model VHS

Vertical Cantilever Recessed Impeller Pumps Designed to Handle Large or Fibrous Solids

- Capacities to 7000 GPM (1590 m³/h)
- Heads to 140 feet (42.6 m)
- Temperatures to 200°F (93°C)
- Pit Depths to 11 feet (3.4 m)*
- Solids to 10 in. (254 mm)

Design Features

Cantilever Design No submerged bearings.

Recessed, Non-Clog Impeller Maximum solid size is equal to pump suction.

Bottom Suction Removes solids from sump floor.

Materials of Construction Available in a wide range of corrosive/abrasive resistant alloys.

Maximum Interchangeability

Replaceable Shaft Sleeve

Services

Mill Scale

Waste Paper Stock

Sludge

Coal Slurry

Black Liquor

Clay Slurry

Plant Waste

Coal Pile Runoff

Food Pulp

Sewage Treatment

Washdown Water

Ash Slurry



Model VHS Vertical Cantilever Recessed Impeller Pumps

Design Features for Handling Large or Fibrous Solids

DIRECT OR BELT DRIVE

Direct drive offers simplicity, ease of installation and low maintenance costs. V-belt drive allows use of readily available standard speed motors along with full diameter impellers to meet desired operating conditions with greater pump efficiency. Belt drive also provides flexibility to meet changes in head/capacity requirements.

HEAVY-DUTY BEARINGS

Grease-lubricated ball bearings located above floor plate, completely sealed from contamination.

CANTILEVER SHAFT — NO BOTTOM BEARINGS

Tapered design operates safely below first critical speed. Ideal for remote locations--no oil or water lines required to lubricate submerged bearings.

BEARING FRAME

Sealed to prevent contamination.

HIGH STRENGTH COLUMN PIPE

Rigidly maintains alignment between bearing frame and casing. Protects pump shaft.

RENEWABLE SHAFT SLEEVE

Full length hook-type sleeve protects shaft.

HUB DISC

Minimizes blow-back of pumpage around shaft sleeve without actual sealing contact.

FULLY RECESSED IMPELLER

Allows passage of solids equal in size to pump suction. Keyed on shaft.

RUGGED ONE-PIECE CASING

Circular design enhances vortex pumping action; dimensioned to allow large solids to pass without clogging.

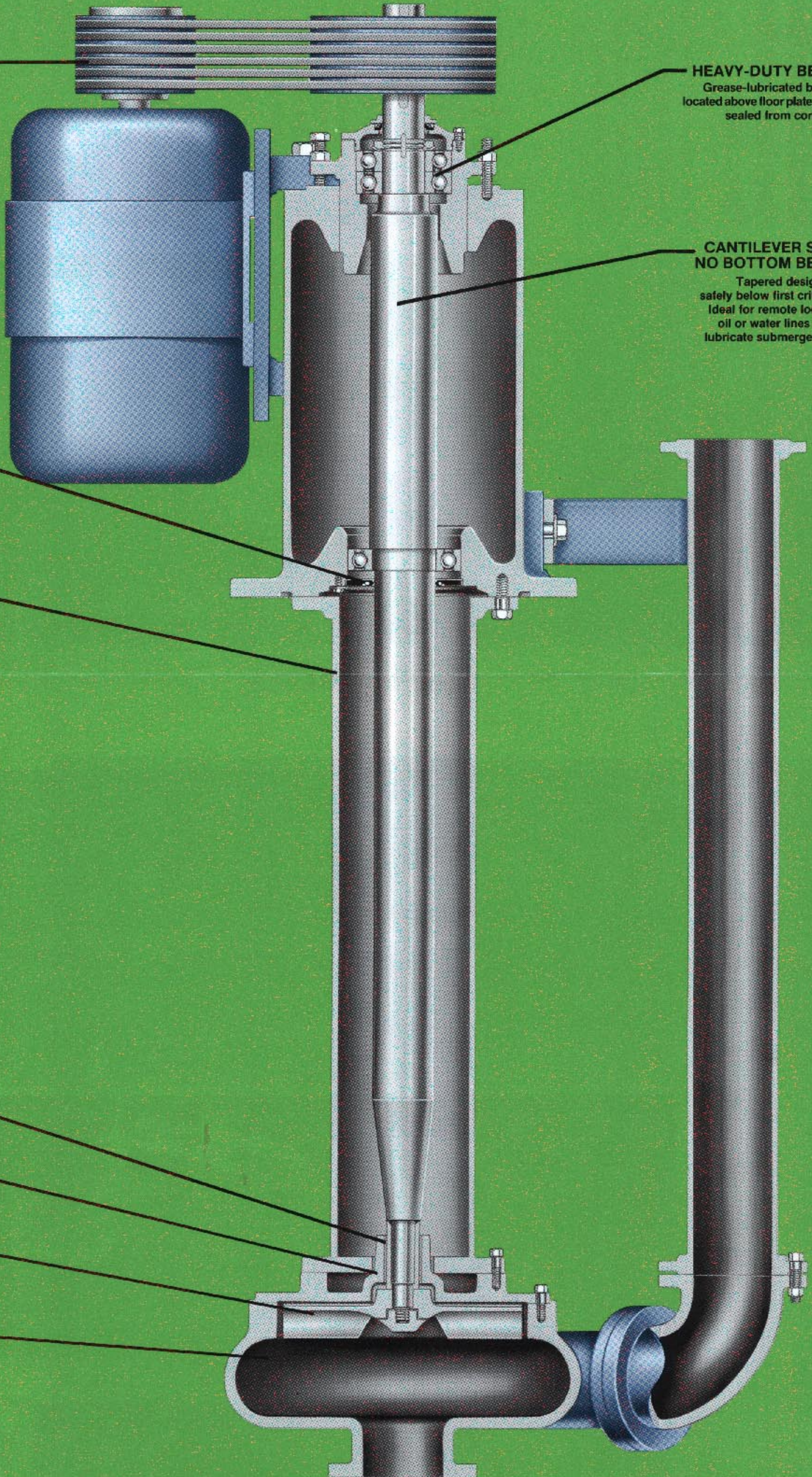

3

4

Application Flexibility

Direct or Belt Drive Goulds offers drive arrangements to meet specific user requirements.

Direct drive offers simplicity, ease of installation and minimum maintenance.

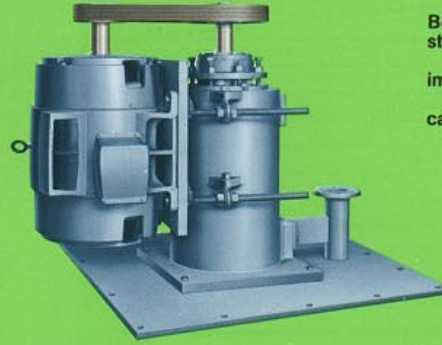

Belt drive allows use of standard speed motors with full diameter impellers. Adapts pump to meet any head or capacity. Extends wear life through low operating speeds.

Optional Floor Plate

Two standard floor plate configurations, circular and rectangular, are available. Custom designed floor plates can be provided.

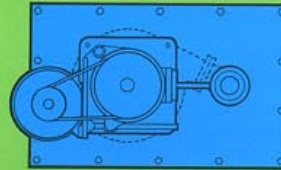

Top View Rectangular Configuration

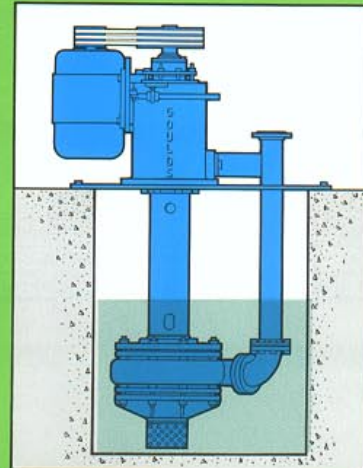

Other Recessed Impeller Pumps

Besides the Model VHS vertical cantilever pump, Goulds makes other recessed impeller pumps for handling large solids.

Model HS Horizontal Solids Handling Pump

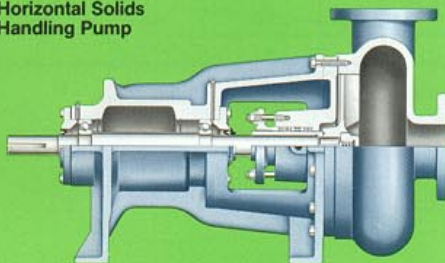

Model HSU Submersible Solids Handling Pump

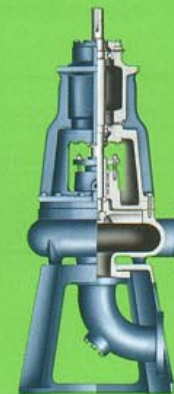

Model HSD Vertical Dry Pit Solids Handling Pump

Parts List and Materials of Construction

Item No.	Part Name	Material		
		Standard		Optional
		Cast Iron	HC600	316 SS
100	Casing	Cast Iron	HC600	316
101	Impeller	Cast Iron	HC600	316
109	Bearing End Cover	Cast Iron		
112	Thrust Bearing	Steel		
122	Shaft	1144 Steel		316
123	Deflector	Rubber		
126	Shaft Sleeve	416		316
134	Thrust Bearing Housing	Cast Iron		
168	Radial Bearing	Steel		
184	Stuffing Box Cover	Cast Iron	HC600	316
192	Pipe Column	Steel		316
195	Discharge Pipe	Steel		316
228A	Bearing Housing	Cast Iron		
304	Impeller Nut	Cast Iron	HC600	316
315	Discharge Elbow	Steel		316
333	Labyrinth Seal	Carbon Filled Teflon		

* For other materials, consult factory

Materials of Construction

Material	Specification
Cast Iron	ASTM A48
HC600	ASTM A532 – Class A hardened
316SS	AISI 316 or ASTM A 743 CF8M
1144 Steel	AISI 1144 free-machining steel

Construction Details

		Pump Size						
		2x2-8	3x3-10	4x4-12	6x6-12	6x6-18	8x8-22	10x10-26
Impeller and Casing	NetWeight—Lbs. (kg)	600 (272)	900 (408)	1100 (499)	1225 (556)	1800 (816)	2400 (1089)	4800 (2177)
	Min. Casing Thickness—in. (mm)	.38 (9.7)	.56 (14.2)	.5 (12.7)	.62 (15.7)	.75 (19)	.75 (19)	.88 (22.4)
	Max. Solid Size—in. (mm)	2 (50.8)	3 (76.2)	4 (101.6)	6 (152.4)	6 (152.4)	8 (203.2)	10 (254.0)
	Working Pressure—PSIG (kPa)	100 (689.5)				70 (482.6)		

Sectional View Model VHS

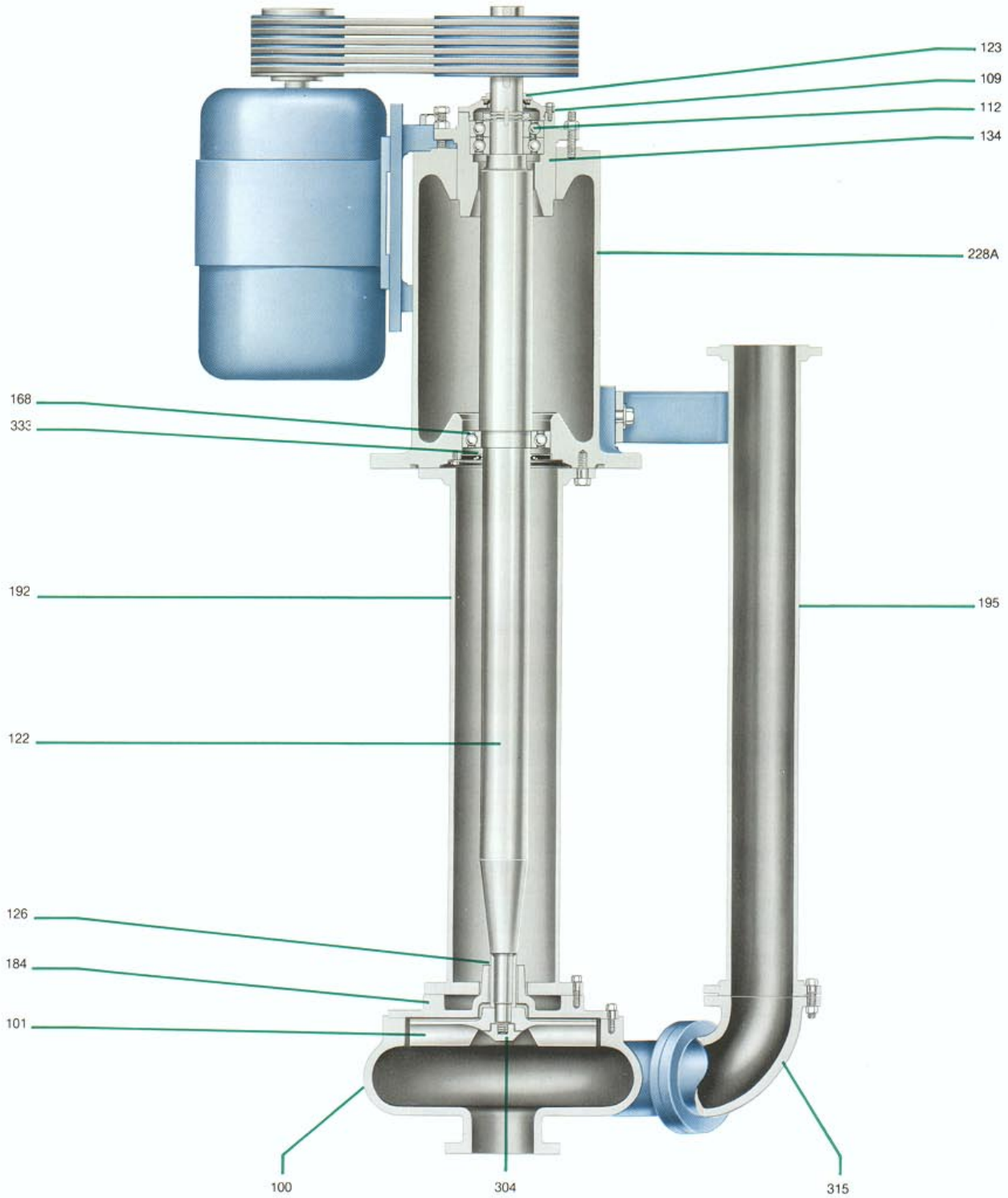

Hydraulic Coverage Model VHS

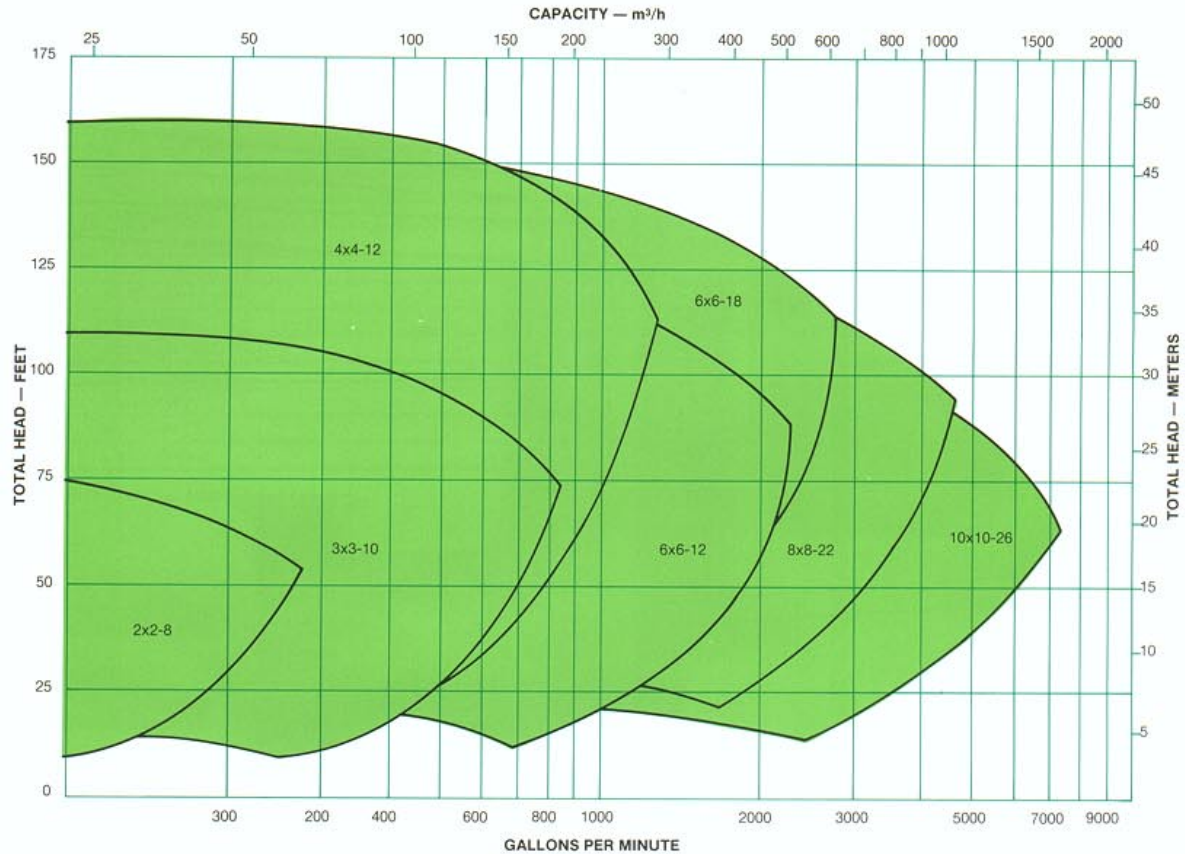

BEARING FRAME DATA								
Bearing Frame	C1	C2	C3	C4	C5A	C5	C6A	C6
Shaft Diameter at Coupling (Size 6x6-12 and Larger)	1.375	2.375	2.875	2.875 (3.375)	2.875	2.875 (3.375)	2.875 (3.375)	2.875 (3.375)
Shaft Dia. Between Bearings	2.625	4.0	5.0	5.75	7.0	7.0	8.125	8.125
Shaft Diameter under Outboard Bearing	2.165	3.150	3.346	4.331	3.346	3.812	4.331	4.50
Shaft Diameter under Inboard Bearing	2.362	3.543	4.724	5.512	6.692	6.692	7.784	7.784
Bearing Span	13.75	24.63	29.25	33.0	29.6	31.75	33.0	34.38
Outboard Bearing	7311 Duplex	7216 Duplex	7317 Duplex	7322 Duplex	7317 Duplex	90381 90744	7322 Duplex	HM926740 HM926710D
Inboard Bearing	6212	6218	6224	6228	61834	23034	61840	2394D
Shaft Diameter below bearing frame (before taper)	2.31	3.5	4.69	5.5	6.63	6.63	7.75	7.75
Maximum Motor Frame Size V-BELT	215T	365T	405T	445T	405T	445T	445T	447T
Maximum Motor Frame Size DIRECT DRIVEN	280HP	400HP	440HP	449HP	440HP	449HP	449HP	449HP
Minimum Horsepower	5 HP							

NOTES:

- 1) Outboard bearings are duplex angular contact bearings on frame sizes C1, C2, C3, C4, C5A, & C6A; and are double row tapered roller bearings on the C5 and C6 frames.
- 2) Inboard bearings are single row deep groove ball bearings on frame sizes C1, C2, C3, C4, C5A, & C6A; and are spherical roller bearings on the C5 and C6 frames.
- 3) All dimensions are in inches.

Dimensions Model VHS

All dimensions in inches (mm). Not to be used for construction.

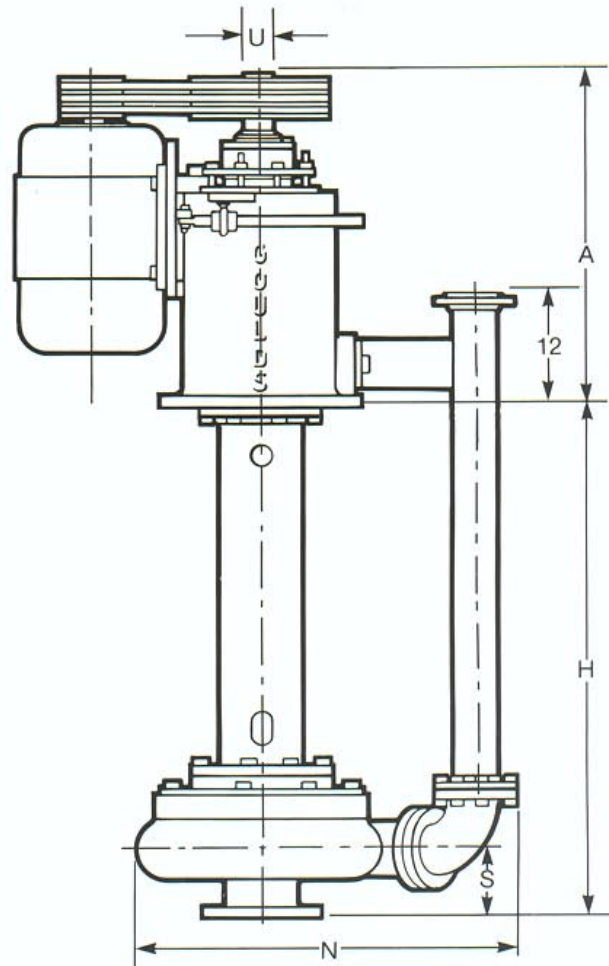
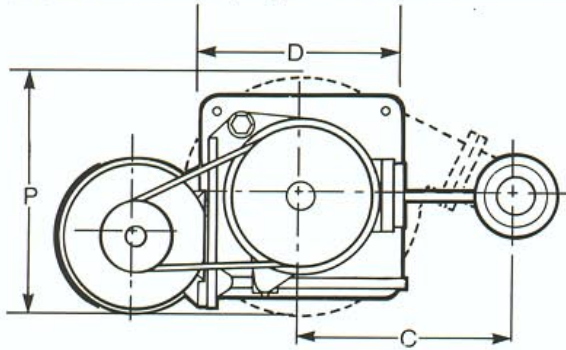

PUMP DIMENSIONS					
Pump Size	C	H	N	P	S
2x2-8	15 (381)	48" (1219) standard. 42" (1067) thru 132" (3353) available in 6" (152) increments.	26 (660)	13 (330)	3 (76)
3x3-10	18.3 (465)		31 (787)	17 (432)	4.5 (114)
4x4-12	19.2 (485)		33 (838)	20 (508)	5.5 (140)
6x6-12	22.1 (561)		41 (1041)	24 (610)	7.5 (191)
6x6-18	25.9 (658)		45 (1143)	29 (734)	7.5 (191)
8x8-22	31.9 (810)		58 (1473)	35 (889)	9 (229)
10x10-26	37.8 (960)		68 (1727)	42 (1069)	10.5 (267)

BEARING FRAME DIMENSIONS						
Frame	C-1	C-2	C-3 & C5A	C-4 & C6A	C-5	C-6
A	23 (584)	38.9 (988)	45.5 (1153)	50.8 (1290)	50.8 (1290)	53.4 (1356)
D	17 (432)	22 (559)	26 (660)	29 (737)	29 (737)	30 (762)
U	1.38 (35)	2.38 (60.4)	2.88 (73.1)	2.88 (73.1)	3.38 (85.8)	3.38 (85.8)

FLANGE DIMENSIONS				
Pump Size	I.D.	O.D.	B.C.	Holes
2x2-8	2	6	4.75	Four — 5/8"
3x3-10	3	7.5	6	Four — 5/8"
4x4-12	4	9	7.5	Eight — 5/8"
6x6-12	6	11	9.5	Eight — 3/4"
6x6-18	6	11	9.5	Eight — 3/4"
8x8-22	8	13.5	11.75	Eight — 3/4"
10x10-26	10	16	14.25	Twelve — 3/4"

One Cantilever Design—Four Pump Models

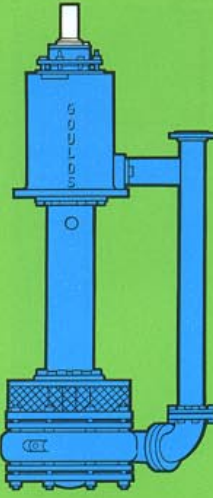
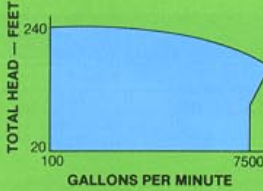
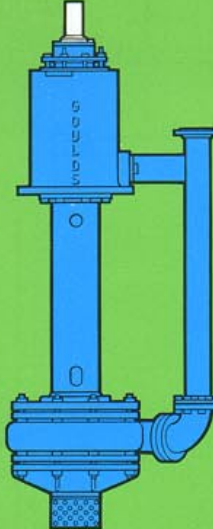
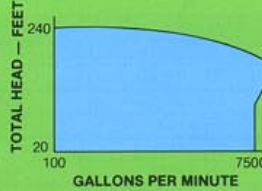
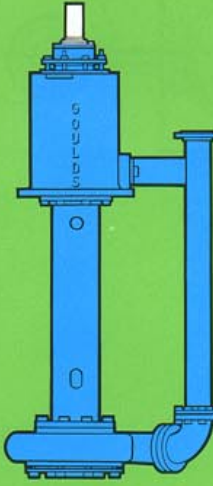
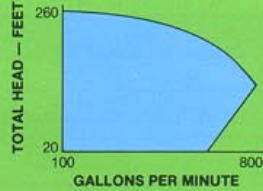
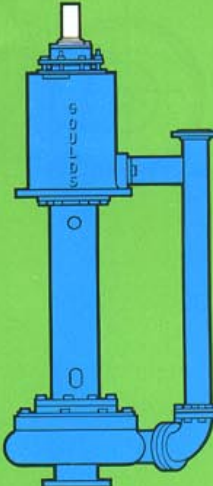
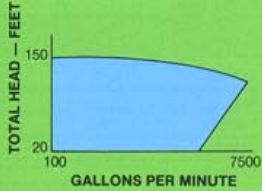
<p>Model 5100 Vertical Cantilever Top Suction Pump</p>  <p>Designed for wide range of corrosive and severe abrasive slurry services. Top suction design eliminates air binding, provides ease of maintenance. Handles abrasive solids to 3-3/8 in. (86 mm). Also available in submerged bearing design for deeper settings.</p> <p>Hydraulic Coverage</p> 	<p>Model 5150 Vertical Cantilever Bottom Suction Pump</p>  <p>For corrosive and extremely abrasive slurry services. Bottom suction removes solids from sump floor. Handles solids to 3-7/8 in. (98 mm). Submerged bearing design available for deeper settings.</p> <p>Hydraulic Coverage</p> 	<p>Model VJC Vertical Cantilever Bottom Suction Pump</p>  <p>Similar to Model 5150, VJC is ideal for corrosives, extremely abrasive slurries. Submerged bearing design also available.</p> <p>Hydraulic Coverage</p> 	<p>Model VHS Vertical Cantilever Recessed Impeller Pump</p>  <p>Designed to handle large or fibrous solids. Recessed, non-clog impeller — maximum solid size is equal to pump suction. Solids to 10 in. (254 mm). Also available in submerged bearing design.</p> <p>Hydraulic Coverage</p> 
--	--	---	--

For more information about Goulds Vertical Cantilever Pumps, call your nearest Goulds sales office or representative.

Visit our website at www.gouldspumps.com

Goulds Pumps



ITT Industries